



STP66 Data Sheet

6" x 6" Self Prime Trash Pump

Pump and parts 100% interchangeable with Gorman Rupp Super-T Series®

Performance Curve

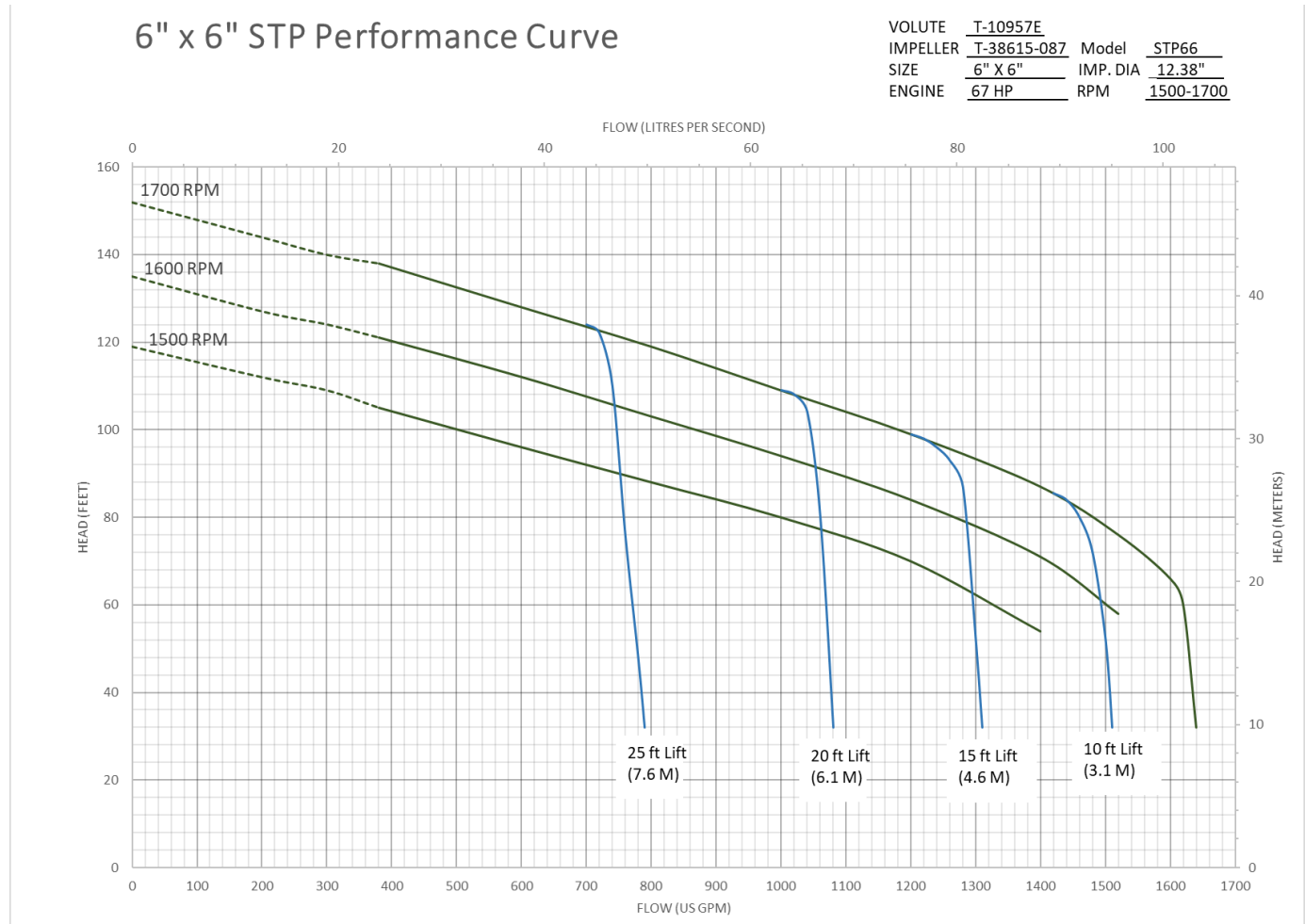

General Specifications

Suction Connection	6 in (150 mm) Flange
Delivery Connection	6 in (150 mm) Flange
Max Flow	1640 USGPM*
Shutoff Head	152 ft
Max Solids Handling	3 in (75 mm)
Fuel Capacity	100 US Gal (416 L)
Max Impeller Dia.	12.38 in (315 mm)

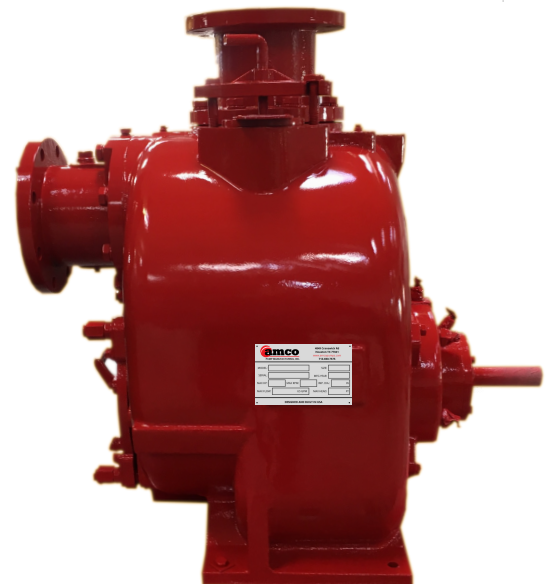

*Larger pipes may be required for maximum flows. A typical picture of an open-unit pump is shown. Please contact Amco Pumps for further details. All information is approximate and for guidance only. Gorman Rupp (R) and Super-T (R) used for reference purposes only.



STP66 Data Sheet

6" x 6" Self Prime Trash Pump

Pump and parts 100% interchangeable with Gorman Rupp Super-T Series®

Dimensions

Weights: 1020 lbs

Dimensions: 36" W x 36" H x 23" W

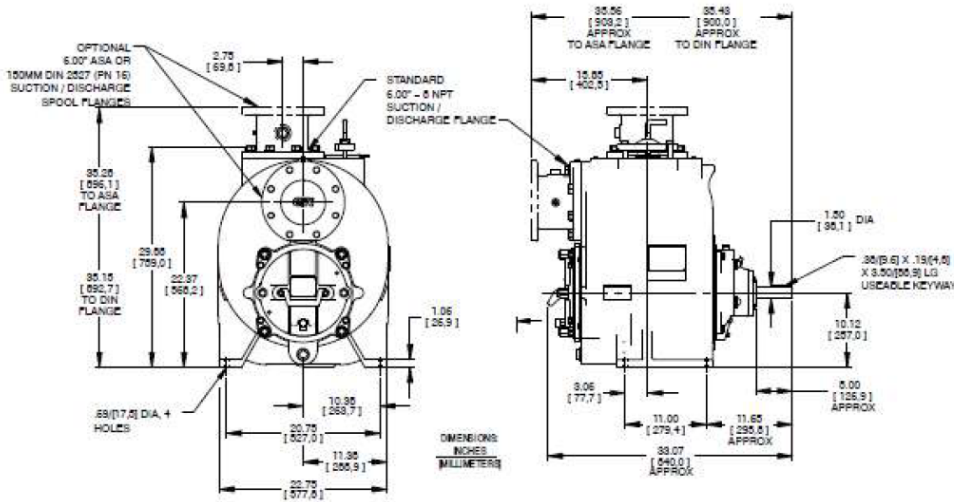

Features

AUTOSTART COMPATIBLE

EASY CLEANING AND CLEARING

INTERNAL INSPECTION CAN BE CARRIED OUT QUICKLY AND SAFELY VIA REMOVAL OF THE CLEANOUT COVER WITHOUT PIPE REMOVAL.

INTERCHANGEABLE PARTS

EASILY REMOVEABLE AND INTERCHANGEABLE ROTATING ASSEMBLY WITH EXISTING PUMPS.

SIMPLE MAINTENANCE

ROUTINE MAINTENANCE IS QUICK AND EASY WITH THE USE OF REGULAR TOOLS

SIGHT GLASSES

BUBBLE SIGHT GLASSES ALLOW FOR EASY VIEWING OF OIL LUBRICATION.

SUITABLE FOR MANY APPLICATIONS

INDUSTRIES WE SERVE INCLUDE



Options

- Diesel or Electric Drive
- Integrated Fuel Tank Skid Mount
- Custom DOT Trailer Options
- Nedox or Epoxy Coating
- Custom Sound Enclosure 69dBA at 30'

Materials

- Durably constructed from Cast Iron parts, ASTM 48, Class 30
- Epoxy paint with poly urethane primer
- SS-316 and CD4MCu Internal wet end components available

Contact Us

713-690-7575

sales@amcopumps.com

www.amcopumps.com

4849 Cranswick Rd.

Houston, TX 77041

24 MONTHS PARTS AND LABOR LTD WARRANTY